

Blue Waters Tips and Tricks

Unix | Linux: [Shell](#)

OS X | macOS: [Terminal](#)

Windows: [Download Putty](#)

Access via SSH

```
ssh traNNN@bwbay.ncsa.illinois.edu
```

Log into Blue Waters

When prompted for a password, enter the password on your account sheet, the first time you log in, you will be asked to provide you name and email address.

Short-Term Password-Less Access (Linux and OSX only, Putty remembers your password)

Add the following snippet to `~/.ssh/config`

```
Host bw
  User traXXX
  LocalForward 9999 h2ologin3:50XXX
  ControlMaster yes
  ControlPath ~/.ssh/ssh-%r@%h:%p
  ControlPersist 10m
```

Now, try:

```
ssh bw
```

Once logged in, you will **not** be asked for your password again if you try to re-connect while the initial connection is still active or within 10 minutes (10m) of its termination. For more useful settings, see: `man ssh_config`

Public/private ssh key pairs are not supported to log into bwbay. Only password based logins are possible.

Using screen (see eg. http://linuxcommand.org/lc3_adv_termmux.php)

<code>screen</code>	<code>start screen</code>	<code>screen -rx</code>	reattach to session
<code>Ctrl-a h</code>	display help text	<code>Ctrl-a d</code>	detach session
<code>Ctrl-a c</code>	create new window	<code>Ctrl-a "</code>	show list of windows

Data Transfer

```
rsync -aP -e "ssh bw ssh" <files> h2ologin3:~/destination/
```

Transfer files **to** Blue Waters

```
rsync -aP -e "ssh bw ssh" h2ologin3:~/folder ./
```

Transfer a folder **from** Blue Waters

- You can use the `bw` shortcut created in [Short-Term Password-Less Access](#) section.
- You can use patterns to transfer specific files only, for example:

```
$ rsync -aP -e "ssh bw ssh" h2ologin3:~/folder/*.zip ./
```

will download only zip files (specified with: `*.zip`) to the current folder (specified with `./`)

```
git push and git pull
```

If you want to change files in a repository.

Starting Jupyter on a compute node

```
./start_jupyter.sh
```

Starts a job and connects to the compute node (it's complicated)

Blue Waters Tips and Tricks

Software Modules

<code>module avail</code>	list modules available on BW	<code>module load <u>module</u></code>	load <u>module</u>
<code>module list</code>	list currently loaded modules	<code>module unload <u>module</u></code>	unload <u>module</u>
<code>module show <u>module</u></code>	show commands within <u>module</u>	<code>module swap <u>mod1</u> <u>mod2</u></code>	swap two modules

Compute node access

You **must not** execute anything compute or memory intensive on the MOM nodes!

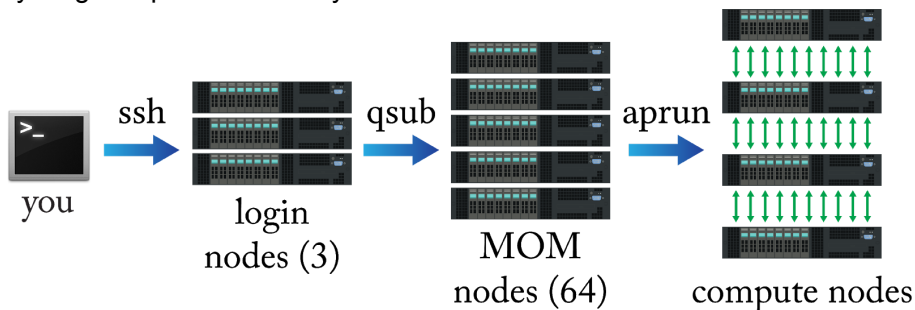

```
laptop$ ssh traNNN@bwbay.ncsa.illinois.edu
h2ologin3$ qsub -I -l nodes=1:ppn=32:xe, -l gres=ccm -l walltime=16:00:00
mom$ module load ccm
mom$ ccmlogin
nidXXXXXX$ jupyter notebook --no-browser
laptop$ ssh -tL 9999:localhost:50NNN traNNN@bwbay.ncsa.illinois.edu ssh -tL 50NNN:localhost:50NNN
h2ologin3 /usr/bin/ssh -p 203 -tL 50NNN:localhost:8888 nidXXXXXX
laptop$ # point your browser to http://127.0.0.1:9999 to connect to jupyter
```

This is an example of an interactive job. `qsub` lands you on one of the MOM nodes where you need to load the `ccm` module and use `ccmlogin` to reach your compute node.

PBS Flags.

<code>-I</code>	request an interactive job	<code>-l nodes=1:ppn=32:xe</code>	request a xe node with 32 cores
<code>-l gres=ccm</code>	request "cluster compatibility mode"	<code>-l walltime=hh:mm:ss</code>	request job run time

